



FONDERIA IN LEGHE LEGGERE 

B. Ferrario

Fonderia di alluminio e leghe leggere dal 1972

www.fonderiaferrario.it



FONDERIA FERRARIO L'AZIENDA

La Fonderia Ferrario opera nel mercato italiano nella Fusione in terra di getti in leghe di alluminio di piccole e medie dimensioni, da un minimo di kg 0,100 ad un massimo di kg 200 per getto.

Dal 1972 una clientela di primaria importanza ne testimonia la serietà e l'affidabilità.

Grande capacità di rinnovarsi adeguandosi alle dinamiche di mercato ed un'organizzazione tecnico - operativa di provata esperienza e flessibilità sono le principali caratteristiche dell'azienda che, nell'ambito delle specifiche tecniche fornite dal cliente, può occuparsi dalla progettazione ed esecuzione dello stampo fino alla rifinitura del prodotto: sabbiatura, pallinatura, trattamenti termici, trattamenti di impregnazione dei materiali e a richiesta lavorazioni meccaniche.

THE COMPANY

At the moment FERRARIO FOUNDRY is operating in the Italian market as to sand castings with aluminium alloys, as to small and medium size, ranging from 0,100 kg as a minimum to 200 kg as a maximum, per each casting. We have been working with very important customers since 1972: they attest our solidity and reliability.

These are our Company's main features: first of all entrepreneurial ability oriented both to rejuvenation and to market dynamics, and then technical-operational structure featured by experience and flexibility.

After receiving the technical specifications from the customer, our Company is able to take care of every step, ranging from designing and producing the pattern to finishing the products: sandblasting, shot blasting, heat treating, metal impregnation treatments and mechanical workings upon customer's request.

LE NOSTRE

ATTREZZATURE

Esperienza ed attrezzature all'avanguardia da sempre rappresentano due importanti punti fermi per Fonderia Ferrario. La nostra fonderia occupa oltre 1500 metri quadri coperti su di un totale di 2500 metri quadri.

FORMATURA

Manuale in staffe che possono raggiungere la dimensione massima di 1500x1500 millimetri, posizionamento anime in manuale.

FORNI FUSORI

N.2 forni fusori da 500 kg e da 300 kg, con capacità fusoria di 200 quintali/mese. I forni sono completi di agitatori e sistema idraulico.

COLATA

Mediante sivere a controllo manuale per portata da 50 a 200 kg. Possibilità di operare con diverse sivere per getti più grandi.

CONTROLLO QUALITA'

Analisi densità e porosità del materiale colato, quantometro per analisi metalli in lega e prove di trazione. Effettuiamo su richiesta prove radiografiche e non distruttive.

**MASSIMA
QUALITA' E UNA
PRODUZIONE
VERSATILE**

FONDERIA FERRARIO

PRODUZIONE

Da sempre attenti alle esigenze dei clienti, la produzione di Fonderia Ferrario pone la qualità al centro dell'attenzione.

La produzione della FONDERIA FERRARIO è da sempre molto varia ed interessa settori disparati che vanno dall'industria all'automotive, dall'arredo al settore motoristico, dal design alla realizzazione di getti a tenuta di gas.

Fondiamo alluminio, leghe leggere e leghe speciali per getti che possono pesare da 0.1 a 200 kg.

La FONDERIA FERRARIO è versatile anche dal punto di vista delle quantità prodotte: possiamo operare per pochi pezzi così come per piccole e medie serie.





MAXIMUM QUALITY AND VERSATILE PRODUCTION

FONDERIA FERRARIO PRODUCTION

Ferrario foundry has always paid special attention to its customers' requests and needs and has always considered quality to be the centre of attention during its manufacturing processes.

The production inside FONDERIA FERRARIO has always been manifold and has involved different fields, ranging from industrial production to the automotive industry, from furniture to motor sector, from design to gastight castings.

We cast aluminium, aluminium alloys and special alloys for castings which can weigh from 0.1 to 200 kg.

FERRARIO FOUNDRY is manifold even when it comes to quantity: we are willing to accept orders relevant to a small number of items and orders relevant to small and medium series.

OUR EQUIPMENT

Expertise and modern facilities has always been very important for Ferrario foundry.

Our foundry extends over 1500 covered square meters, while the building covers an area of 2500 square meters as a whole.



MOULDING

Ferrario foundry carries out manual moulding into moulds which can have dimensions up to 1500 x 1500 mm. The cores are placed manually.



FURNACES

In our foundry there are two furnaces: the first one melts 500 kg, the second one melts 300 kg; their casting capacity is 20 tons a month. The furnaces are equipped with rabble and hydraulic system.



POURING

The pouring is carried out by manual ladles as to the following capacity: from 50 to 200 kg.

Ferrario foundry can use more than one ladle for heavier castings.



QUALITY CHECK

Density and porosity tests, quantometer for analysing metal alloys and stress-strain test.

We can carry out also radiographic analysis and non-destructive tests upon customer's request.

DALLA PROGETTAZIONE ALLA CONSEGNA

FROM PLANNING TO DELIVERY

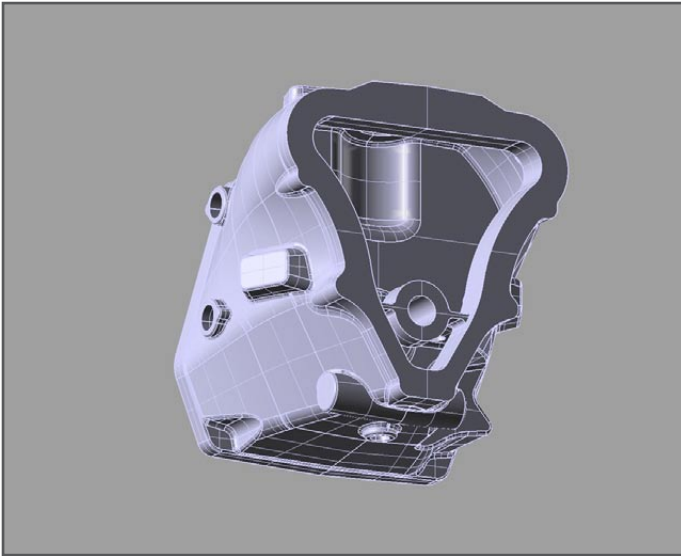

PRODUZIONE

AUTOMOTIVE, INDUSTRIA



Visita la nostra
PHOTO GALLERY:
collegati al sito
www.fonderiaferrario.it

Fonderia Ferrario Automotive ed Industria

FONDERIA FERRARIO opera normalmente su fusioni destinate ad ogni settore dell'automotive e dell'industria in genere.



Please visit our
PHOTO GALLERY:
visit our website
www.fonderiaferrario.it

Fonderia Ferrario
Automotive and Industry

FONDERIA FERRARIO usually carries out castings for every area of the automotive industry and in industrial production on the whole.

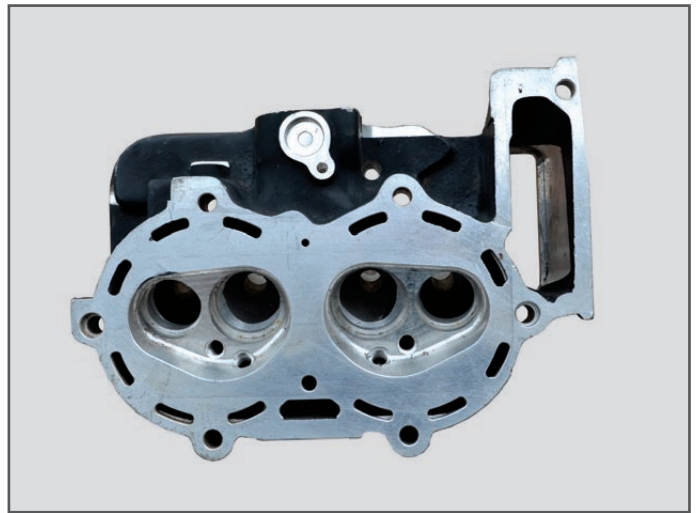
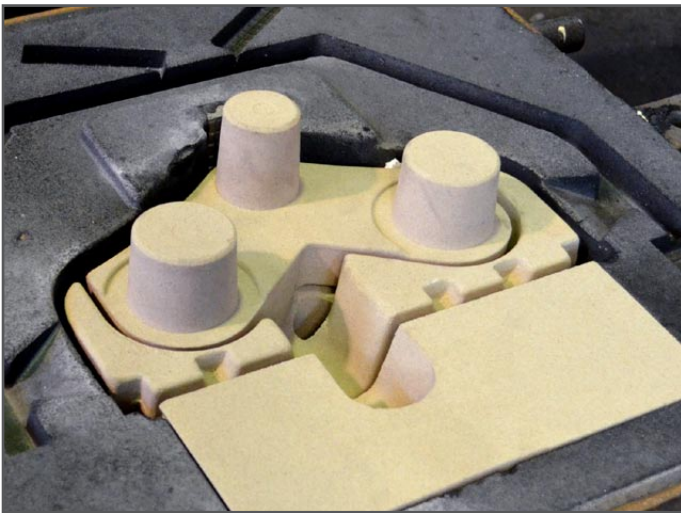
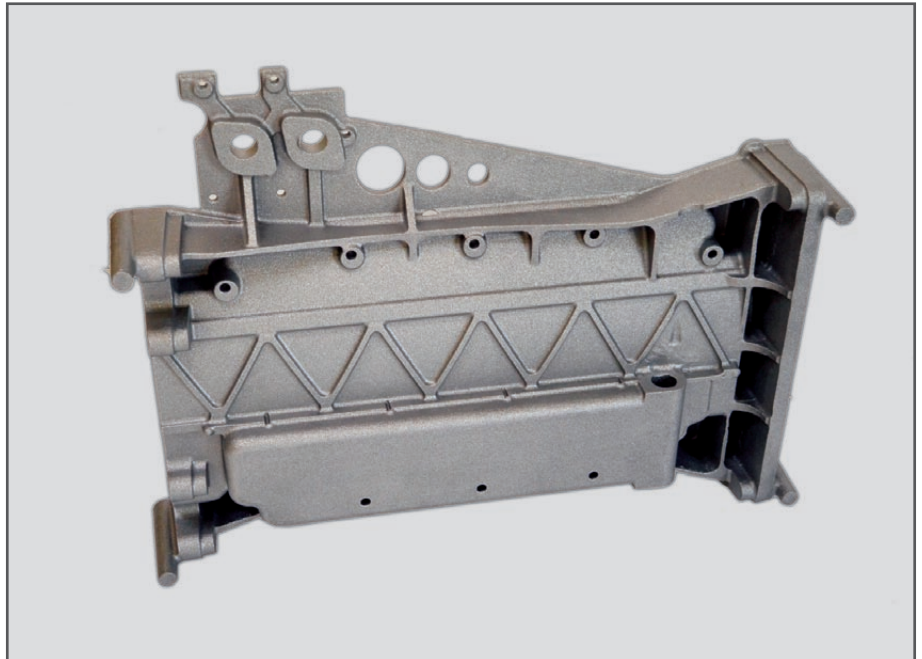

PRODUZIONE

AUTOMOTIVE, INDUSTRIA

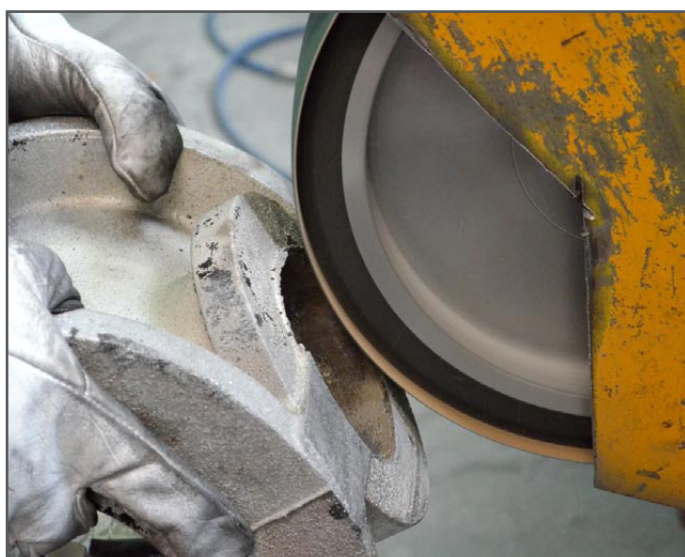

PRODUCTION

AUTOMOTIVE, INDUSTRY

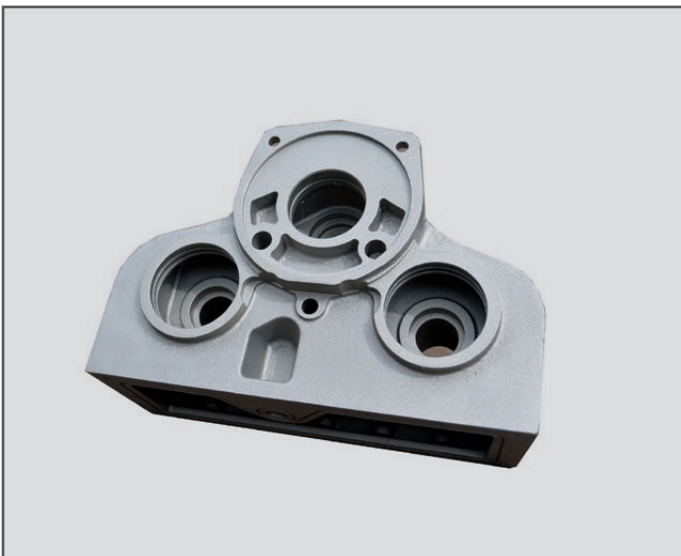
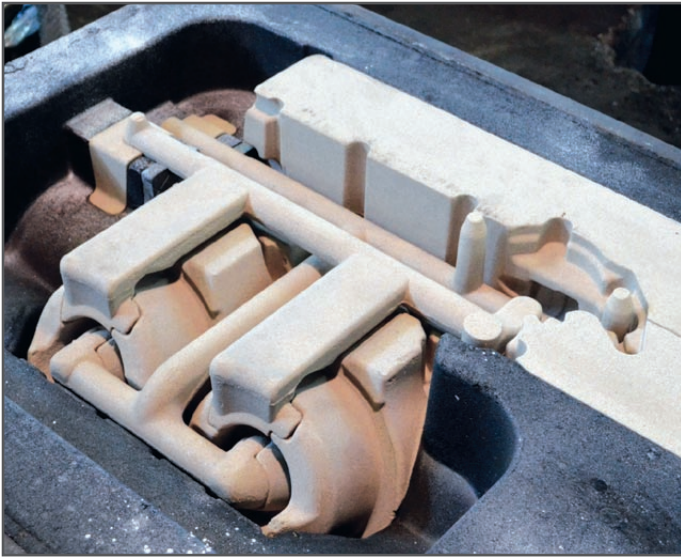

PRODUZIONE

ARREDO E STILE

I primi articoli di arredo realizzati da **FONDERIA FERRARIO** risalgono ai primi anni 90, con panchine e tavoli da esterno.

Da allora la produzione si e' estesa e ad oggi **FONDERIA FERRARIO** produce:

- Arredo urbano
- Colonnine per bike sharing
- Panchine e tavoli per esterno
- Decorazioni per recinzioni
- Complementi d'arredo per giardino

Da diversi anni, inoltre, **FONDERIA FERRARIO** produce piastrelle e oggetti di arredo di design per interni o per esterni.

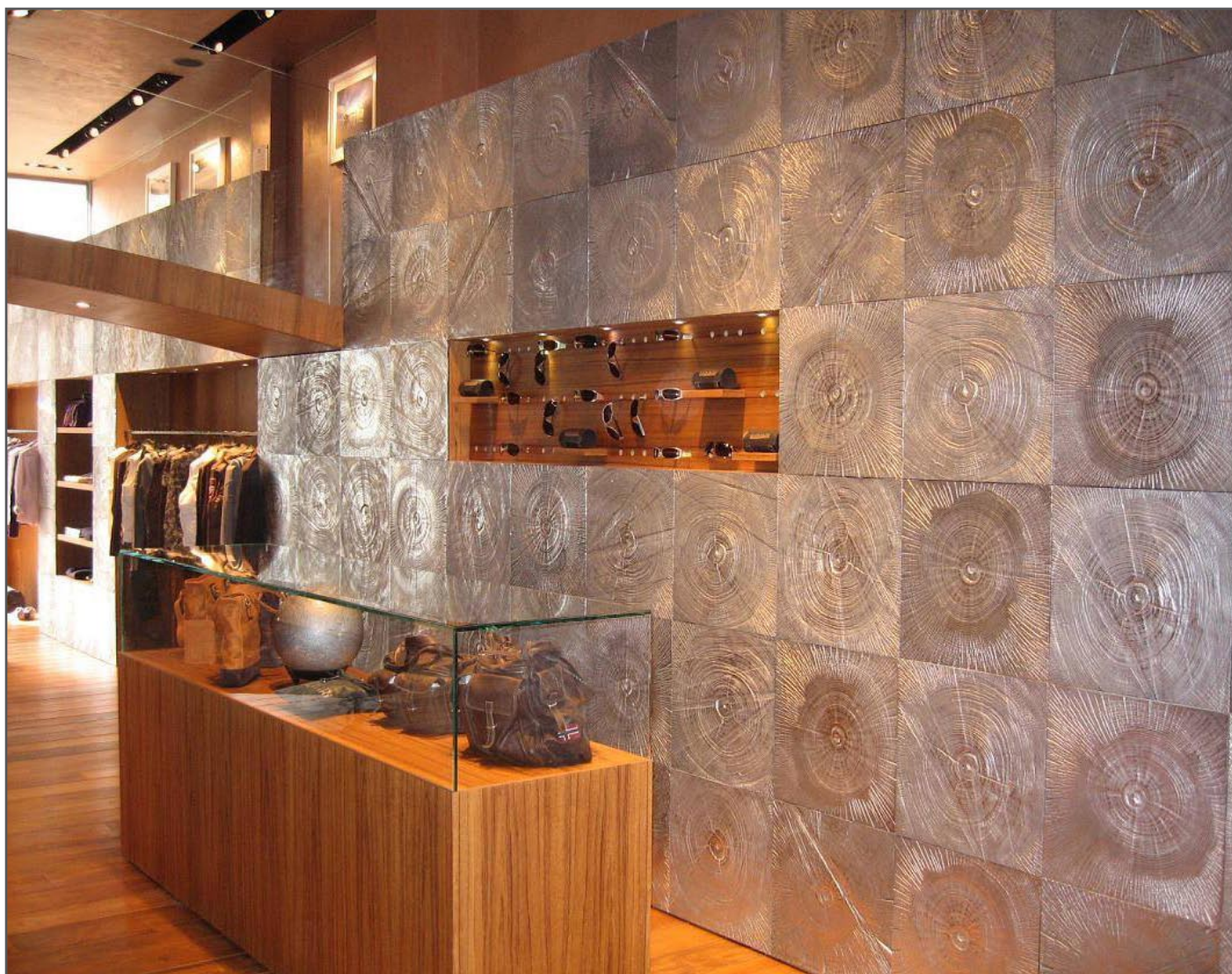

PRODUCTION

FURNITURE AND STYLE

As to furniture, in the early 90s, **FERRARIO FOUNDRY** produced its first items, that is benches and garden tables. From then on, this range became wider.

This is the full list of the items produced by **FERRARIO FOUNDRY** nowadays:

- Street furniture
- Little columns for bike sharing
- Benches and garden tables
- Decorations for gates and fences
- Outdoor furniture and complements.

In addition to all this, three years ago, **FERRARIO FOUNDRY** started producing tiles and both outdoor and indoor design furniture.





FONDERIA IN LEGHE LEGGERE 

B. Ferrario

CONTATTI

Via Per Turbigo 22
20022 Castano Primo (MI) - ITALY
Tel +39.0331.880.362
Fax +39.0331.877.588
info@fonderiaferrario.it
www.fonderiaferrario.it

